

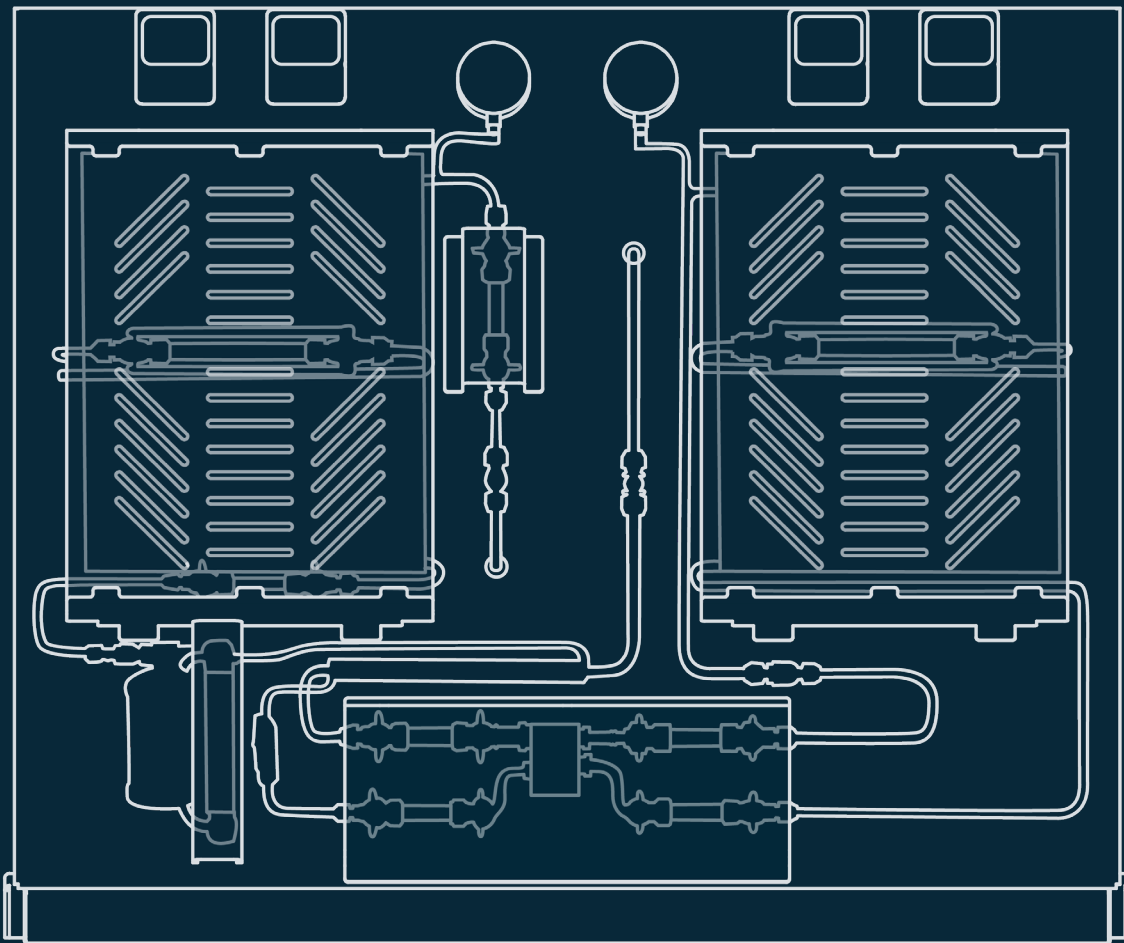

# Air conditioning system trainer with H-Block





The ConsuLab EM-2000-HB Air Conditioning trainer is a complete A/C system with unique features designed to enhance the instruction of air conditioning physics. The trainer uses the H-Block TXV design of refrigerant flow control. The trainer uses common automotive components and can be used in both classroom and shop environments. The trainer utilizes a hermetically sealed and internally protected compressor. Operates on 120V 15A 60Hz circuit.

## EDUCATIONAL ADVANTAGES

- Trainer has all major components required for an automotive air conditioning system using the H-Block TXV system.
- Fully operational with typical component layout and organization.
- Clear sight glasses provide clear understanding of the H-Block (TXV) air conditioning refrigeration cycle.
- Allows student observation of refrigerant changes of state (liquid/vapor) at the receiver/drier, evaporator and condenser.
- Trainer can be connected to any A/C Recycling/Recovery equipment using R134a service ports.
- Allows visual inspection of the role and operation of the H-Block (TXV) and receiver/drier.
- Provides pressure and temperature measurement displays of evaporator and condenser.
- Allows the introduction of system restrictions and blockages for diagnostic learning.
- Adjustable fan speeds for demonstrations of typical performance problems for evaporator and condenser.
- Removable magnetic component identification labels and refrigerant flow arrows for student learning.
- Equipped with high pressure cut-out switch, evaporator deicing switch and internal compressor protection.
- High and low side ball valves can be adjusted to demonstrate various system restrictions resulting in abnormal operation.
- Trainers condenser, evaporator and compressor cycling switches can be adjusted to demonstrate various abnormal symptoms.

## FEATURES

- OEM R134a service ports.
- High and Low side A/C pressure gauges.
- Adjustable temperature control switch for evaporator temperature levels.
- Digital thermometers (4) at inlet and outlet of evaporator and condenser.
- Internally protected hermetically sealed A/C compressor.
- A/C compressor has manual starter with internal thermal protection.
- High pressure (300psi) safety switch shuts off compressor.
- Adjustable 3-speed evaporator (1) and condenser (2) fans.
- Cycling switch bypass toggle switch.
- Stainless steel condensate drip pan with drain.
- Power "ON" indicator light.
- Removable magnetic component name and refrigerant flow arrow labels.
- Operation Manual and Curriculum with student assignments included.

## TECHNICAL INFORMATIONS

- Operates on a 120V 15A 60Hz circuit.
- Refrigerant: R134a (20 oz) (568 g).
- Refrigerant Oil: Ester 100 ISO, viscosity at 100.
- Sturdy powder coated metal stand with two locking swivel and two fixed casters.
- Dimensions: 30 x 43.5 x 66.75 inch (76.2 x 110.5 x 170 cm) 48 x 40 x 68 inch (121.9 x 76.2 x 172.7 cm) with packaging.
- Weight: 222 lb (100.7 kg) / 310 lbs (140.6 kg) with packaging.



Scan this QR code for more about this product

**FIRST**  
**TECHNOLOGIES INC.**  
*Putting Education . . . FIRST*

Toll Free: 800-787-9717      Email: info@firsteched.com  
 Phone: 262-753-6900      www.firsteched.com  
 Fax: 262-753-6901

